



**CHILL TECH**

Refrigeration & Cold Storage Trading LLC

# Innovative Storage Solutions

Product Catalog 2024

# Innovative Refrigeration & Storage Solutions for a Better Tomorrow

Welcome to ChillTech, where innovation meets reliability. We specialize in advanced refrigeration solutions and supermarket equipment tailored to your unique business needs. Our mission is to provide cutting-edge products and exceptional customer service that enhance your business's efficiency and effectiveness.

## Comprehensive Refrigeration Solutions

ChillTech offers a wide array of refrigeration options designed to suit a variety of industries. From island freezers to display refrigerators, our products incorporate the latest technology to ensure optimal cooling and energy efficiency. Whether you operate in the food and beverage sector or the retail industry, we have the perfect solution for you.

## Complete Supermarket Equipment

Beyond refrigeration, Chill Tech provides a complete range of supermarket fixtures and equipment. Our offerings include shelving, racking systems, trolleys, cash counters, and more, ensuring smooth business operations. As a one-stop shop for your retail equipment needs, we simplify the process of setting up or upgrading your store.

## Outstanding After-Sales Service

Our commitment to customer satisfaction doesn't end at the point of sale. We provide an extensive after-sales service, including an exclusive warranty, to give you peace of mind. Our dedicated support team is always ready to assist you with any issues, ensuring your business runs smoothly.



**CHILL TECH**  
Refrigeration & Cold Storage Trading LLC



# Mission

ChillTech's goal is to lead in refrigeration and supermarket services. We build strong client relationships by offering top-quality products, personalized service, and dependable support. We help businesses thrive in a changing market.

# Vision

At ChillTech, we deliver innovative refrigeration solutions and supermarket services tailored to meet our clients' unique needs. We focus on quality, reliability, and customer satisfaction while committing to eco-friendly practices for a sustainable future.



**Our  
Products →**

# LOTUS SL

The products, which are displayed inside of the Lotus model, which provides large display area because of its low base, can also be reached quite easily.

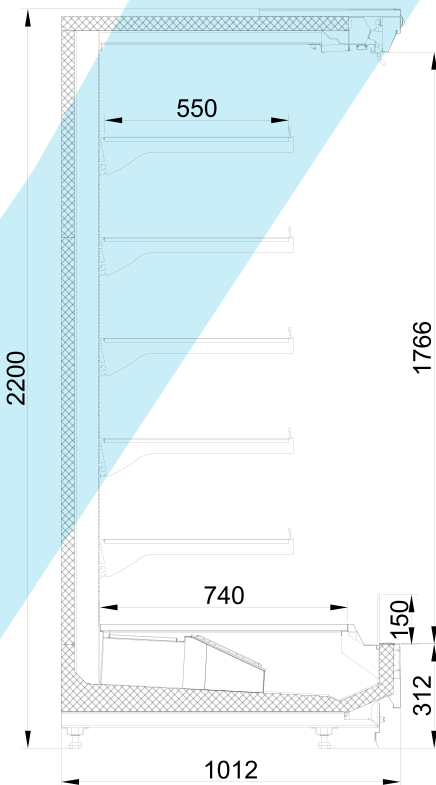

Side panels can be applied with double glazing, with mirror or as covered.



*Plexi Product Stopper*



*Plexi Product Divider*



*Hook Bar*



*Meat Hanger Bar*



*Shelf Lighting*



*Wire Base Divider*



*Wire Base*



*Wire Basket*



# MANOLYA NL

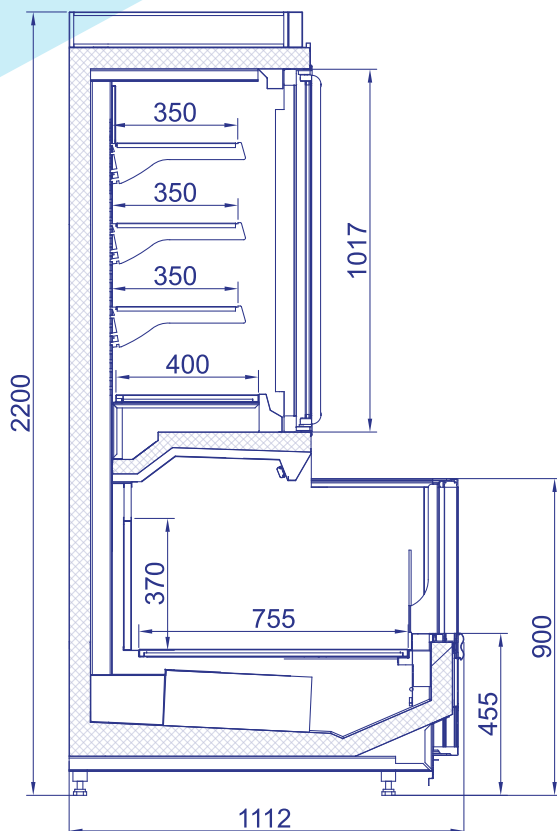

MANOLYA LM-HD-2200



Night Blind



Glass Sliding Cover



Wire Product Divider



Wire Shelf



Wire Base



# ERGUVAN NL



Night Blind



Wire Product Divider

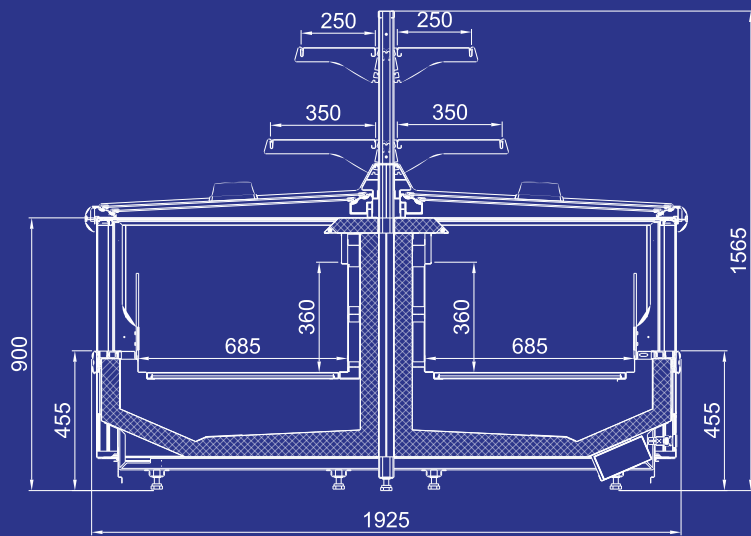

ERGUVAN SRG



Wire Base



Glass Sliding Cover



Shelf Systems

# AKASYA

V1

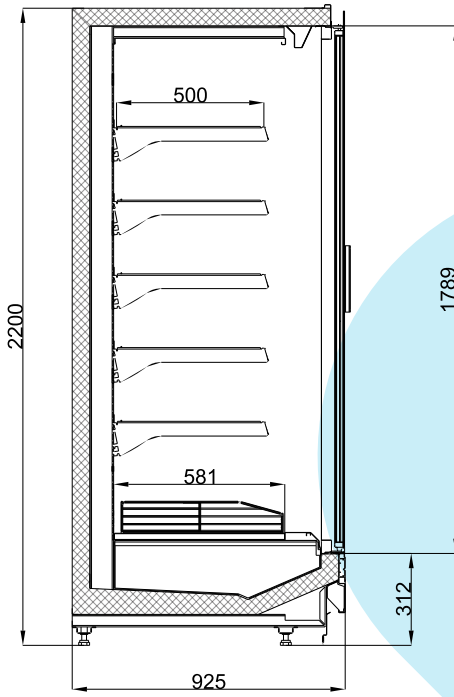

AKASYA FG SKY



Plexi Product Stopper

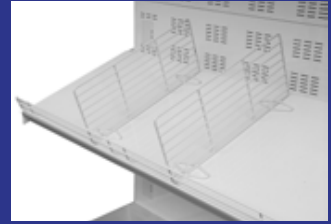

Wire Base Divider



Wire Basket



Wire Base



# ACELYA ML

Açelya model has been designed in order that the packed meat, milk and delicatessen products could be displayed in limited spaces in the best way.

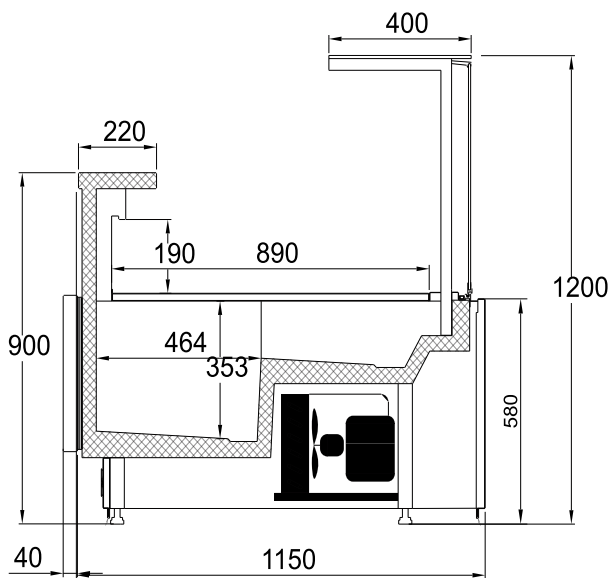

### Available Sizes

**1150** x **2815** x **1200**  
Width Length Height

**1150** x **1875** x **1200**  
Width Length Height

**1150** x **1250** x **1200**  
Width Length Height

AÇELYA GL-FG-SL / ML

# PAPATYA ML

Papatya model, which works as a plug-in, is designed for small shops and limited spaces for the best preservation and display of frozen products. It has high energy efficiency thanks to its robust design with innovative design.

Available Sizes				
840	x	1875	x	2070
Width		Length		Height
840	x	1250	x	2070
Width		Length		Height

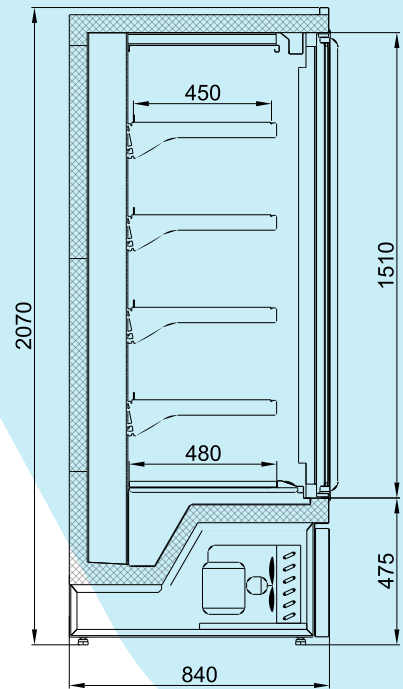

PAPATYA LM HD



# FULYA

It provides ease of use for placement of the products and for the display because of its shelves that could be adjusted vertically and at an angle.

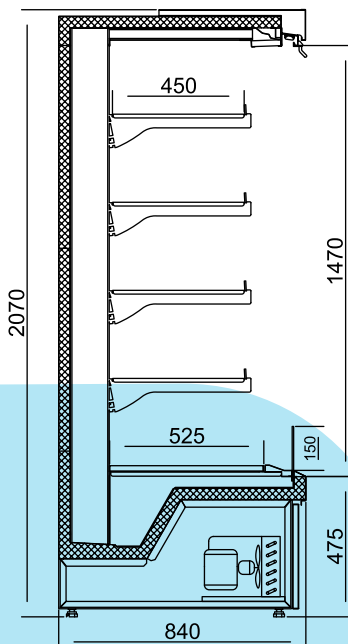

FULYA PN SL/ML

You can show your displayed products more lively with the use of under shelf illumination that is supplied as an option.

### Available Sizes

**820** x **1350** x **2050**  
Width Length Height

**820** x **1975** x **2050**  
Width Length Height

# NERGIS FG

Designed Self-contained Nergis PLG, which guarantees an outstanding presentation of packaged meat, dairy, delicatessen and beverage products. It has high energy efficiency thanks to its robust design with innovative design.



# MELISA

Melisa can be placed in front of a wall (wall type) and/or can be installed back to back (island type). Its multi-storey display area allows you more space for displaying dairy, charcuterie, fruits, vegetables and beverages.



# INCI

inci is an ideal choice for store owners through its elegant design, who wish to put the stylishness and ease of use at the forefront in their stores. It has been designed for packed meat, milk, delicatessen, fruit/ vegetable products and for drinks. It has high energy efficiency thanks to its robust design with innovative design.



# LALE

The products, which are displayed inside of the Lale model, which provides large display area because of its low base, can also be reached quite easily.





# ANTORYUM

Antoryum is designed for displaying all fast-moving consumer goods (FMCG) such as drinks, desserts, sandwiches and salads and it is coming with three level of wide shelves. This is one of the most suitable option for gas station, cafe, patisserie, mini markets where there is not large places for refrigerated cabinets.

# KAZABLANKA

Plug-in Casablanca model that provides excellent product visibility with its highly transparent glass structure; It can operate in both positive (3M1 & +2/+4) and negative (3L1 & -20 / -22) cooling classes with its high-tech “convertible” structure. With this advantage, our cabinet allows the display of both packaged meat, milk, delicatessen and beverage products as well as frozen products.



# HERCAI GM

Hercai GM can be placed in front of a wall (wall type) and/or can be installed back to back (island type). Its multi-storey display area allows you more space for displaying dairy, charcuterie, fruits, vegetables and beverages.

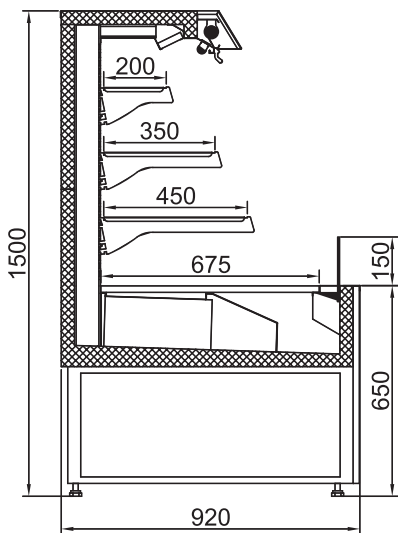

HERCAI GM

This cabinet is one of the preferable semi height chiller with wide range of color options that you can definitely give a chance for your projects such as shopping center, as remote or plug-in based on your choice.

### Available Sizes

1250 & 1850 & 2500

Length

2050

Height

# DEFNE

Defne model, which has been designed for displaying ice cream and packed frozen products as wall side rayon, is the frequently preferred product especially by supermarkets and hypermarkets. There are night curtain and sliding covers are available as option. It would also add an stylish atmosphere inside of your store with its rich colour options and with its aesthetic modular structure at corners.



# LEYLAK

Leylak model, which has been designed as four side glass wide for displaying ice cream and packed frozen products, is the frequently preferred product especially by supermarkets and hypermarkets.

There are night curtain and sliding covers are available as option. Because of Leylak model has four side glass it provides opportunity of displaying your products and shopping from four side. It would also add an stylish atmosphere inside of your store with its rich colour options and with its aesthetic modular structure at corners.



# ORKIDE

Orkide model has been designed in order that the packed meat, milk and delicatessen products could be displayed in limited spaces in the best way.



# MELISA



Its beverage and packaged product display unit is perfect for positioning at cash register and other purchasing areas to encourage instant product purchases.

Led canopy lighting enhances the inviting tone of the cabinet, while adjustable shelving units provide flexibility to showcase different product options.

The compact size of the cabinet allows easy relocation to optimize store layout.

# REYHAN

Reyhan is designed for refrigerated display of fruits and vegetables with its wide display area. You can choose your favorite color from our wide range color options or you may want to have a wood touch to suit your store design in a better way.



# LILYUM

Plug-in Lilyum model, which has been designed for displaying packed dairy products is the ideal selection for supermarkets and hipermarkets with its design which is maximizing product visibility, rich colour options, self service opportunity, with its ease of movement capability.



# AURA



With Transport Band **160 4002+**

Without Transport Band **160 4001+**



# PENGUEN 105 SLH

- Remote Unit
- Ultra Slim Depth
- Slow Rise Night Blind
- Digital Controller
- Base +5 Adjustable Shelf
- Pvc Bump Strips
- Class 3M<sup>2</sup>

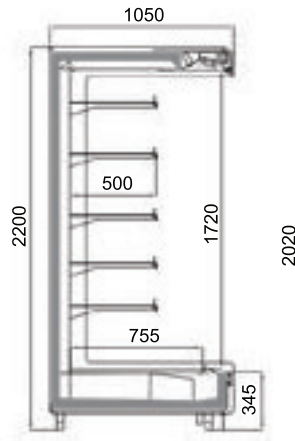

### Available Sizes

**3750** x **1050** x **2200**  
Width Length Height

**2500** x **1050** x **2200**  
Width Length Height

# TUNA VG DISPLAY COUNTER REMOTE

Size  
**2500** x **2815** x **1875**  
Width Length Height

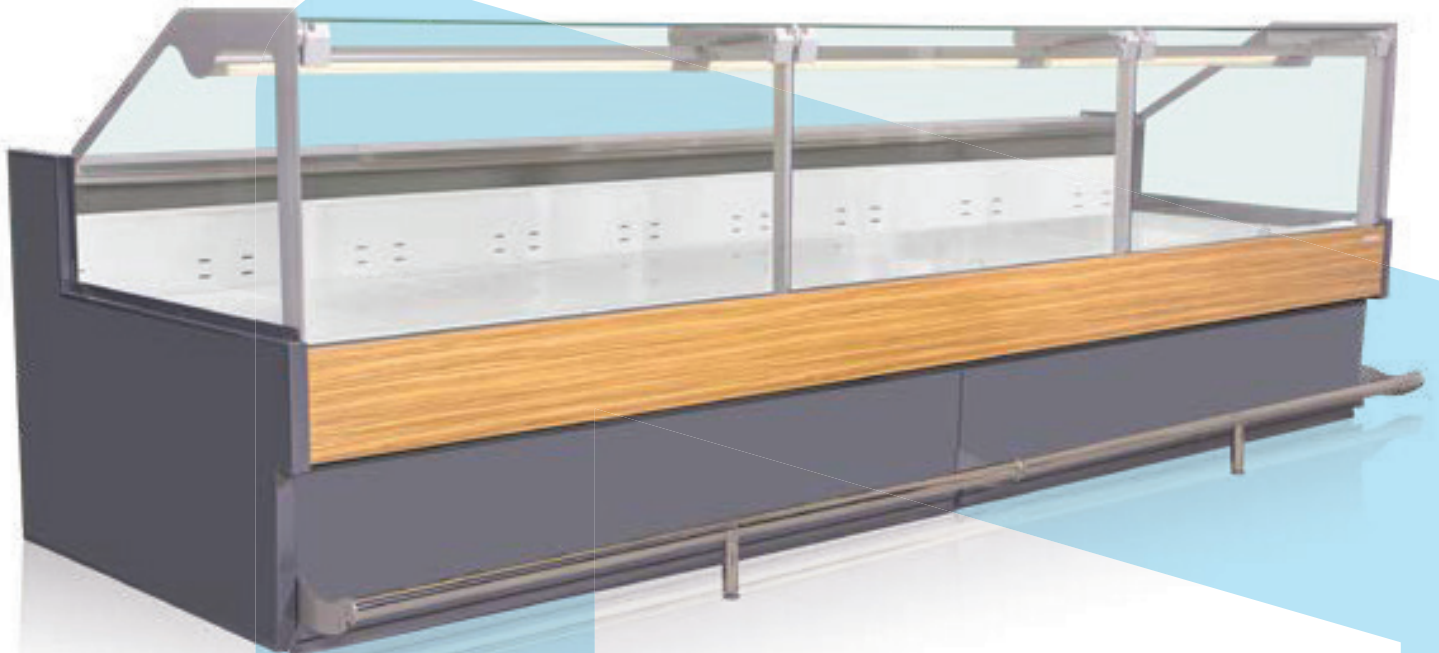



# NICE MULTI DECK

## PLUG-IN WITH GLASS DOOR & OPEN PLUG-IN WITHOUT DOOR

- Class 3M2 (-1°C / +7°C)
- Low front Integral Multideck
- 5 x 400mm shelves + base
- Slide out machinery tray
- Full vision panoramic or mirrored end walls
- Water evaporation tray
- Automatic defrost
- Multiplexable
- Digital controller
- Slowrise night blind
- Shelf strengtheners as standard
- Perspex shelf risers

### OPTIONS

LED Canopy Lighting

LED Shelf Illumination

EC Fans

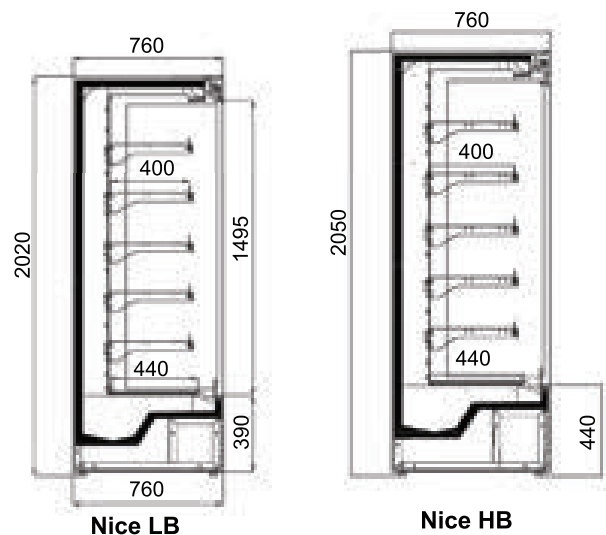

Slide out condensing unit tray

# FREEZER COMBINATION

ZM14X-L01  
+ HN14A/ZTS-U

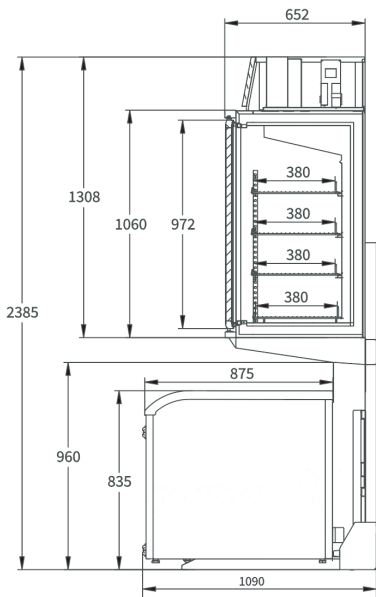

- Increasing display area
- Multiple combination choices
- Top cabinet fridge available
- Auto defrosting
- RAL colour choices
- Optimized height & display design

# SMALL FREEZER COMBINATION

ZM21B/X-L01+HN21A/ZTB-U

ZM25B/X-L01+HN25A/ZTB-U

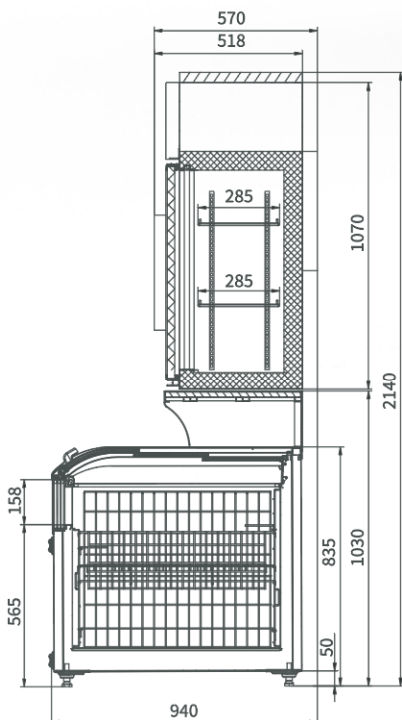

#### Available Sizes

1200 x 940 x 2140

Width

Length

Height

1470 x 940 x 2140

Width

Length

Height

- Increasing display area
- Multiple combination choices
- Top cabinet fridge available
- Auto defrosting
- RAL colour choices
- Optimized height & display design

# DISPLAY CASE

## GLASS DOOR UPRIGHT

BR60

BF60

One Door

600

x

760

x

2000

Width

Length

Height



BR120

BF120

Two Door

1200

x

760

x

2000

Width

Length

Height





# DISPLAY CASE GLASS DOOR UPRIGHT

BB180

BF180

Three Door

600

Width

x

760

Length

x

2000

Height



- Perfect refrigeration effect and high energy saving
- Plug-in and different sizes can be freely combined.
- SECOP compressor, EBM fan motor
- Self-closing, Low-E glass door, 2 layers chiller glasses.
- 3 layers freezer glasses with heating
- Self-evaporate tray
- CE and ETL certificate

# ISLAND DOUBLE SIDE FREEZER

- Remote Control Unit
- Polyurethane Body
- Double Evaporator exp. with Valf Bumper
- Digital Termostat
- Air-frost System
- Head Cabinet Option
- Class 3L1 (-15°C / -18°C)
- Class 3L2 (-12°C / -15°C)



## OPTIONS

- Slow Rise Night Blind
- Wire tray and divider
- Sliding Glass Door
- Super structure  
2 row shelf with light

Island 1

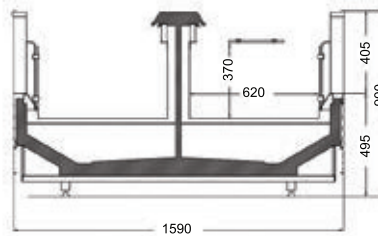

Island 2

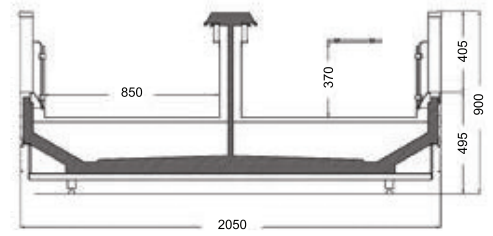

# PLANET GLASS DOOR FREEZER

- Class 3L1 (-15°C / -18°C)
- 2, 3, 4 and 5 door models available
- Heated frame and Glass Doors
- 4x420 mm. adjustable wire shelves
- Epos price strips
- Shelf closing doors
- T5 light
- R404a, R407f, R449a, R744

## OPTIONS

- Extra Shelves
- EC Fans
- Led Pillar Light
- Anti Fog Application on the Glass

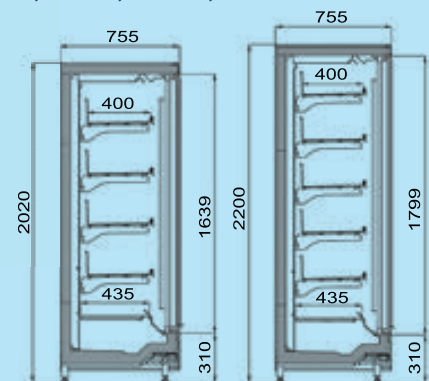

# ISLAND FREEZER

## ASIAN STYLE TRANSPERENT

### HW18A/ZTB-U

- Widened transparent window
- Evaporator refrigerating
- Layers front glass
- User-friendly handles
- Larger opening area
- Auto defrosting
- RAL colour choices
- Imported compressor

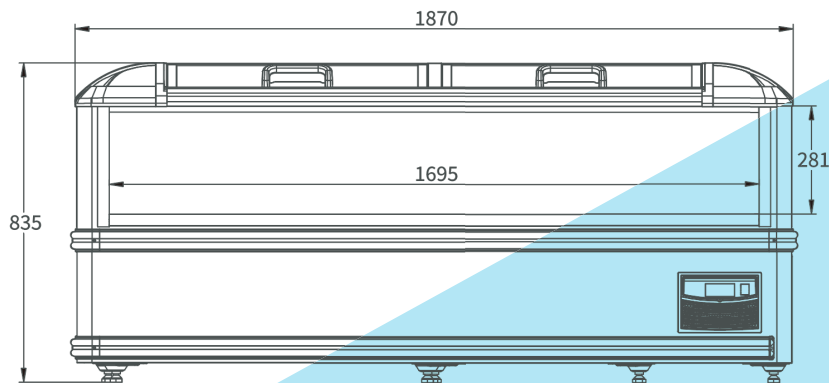

# ISLAND FREEZER

## ASIAN STYLE TRANSPERENT

HN21A/ZTB-U

HN25A/ZTB-U

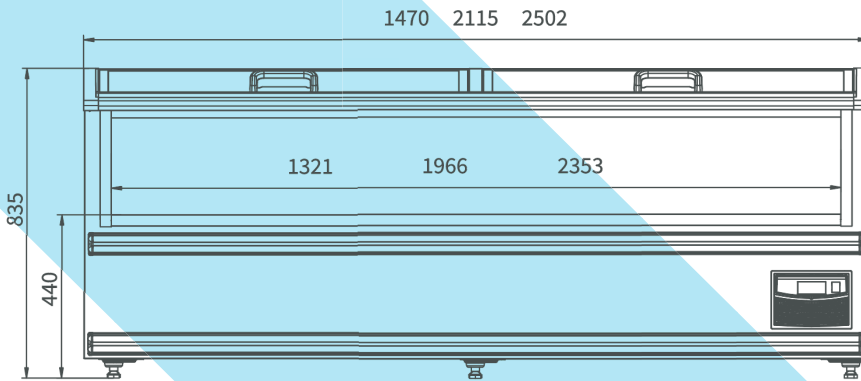

### Available Sizes

2115 x 875 x 835

Width Length Height

2502 x 875 x 835

Width Length Height

- Widened transparent window
- Evaporator refrigerating
- Layers front glass
- User-friendly handles
- Larger opening area
- Auto defrosting
- RAL colour choices
- Imported compressor

# ISLAND FREEZER CHINESE TRANSPERENT

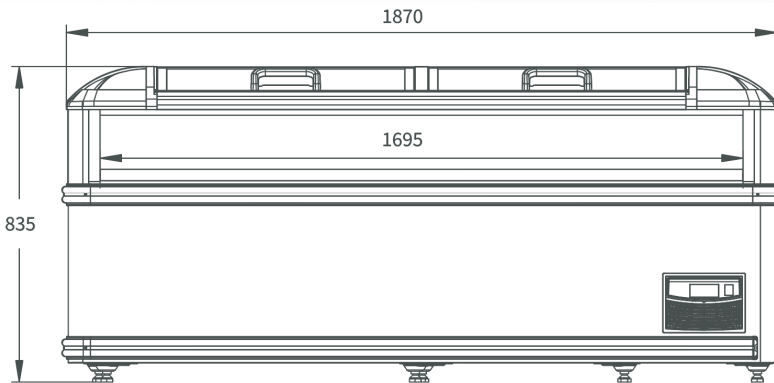

HW18A/ZTS-U

- Front transparent window
- Layers front glass
- User-friendly handles
- Larger opening area
- The lowest temperature:  $-25^{\circ}\text{C}$
- Evaporator refrigerating
- RAL colour choices
- Auto defrosting

# ISLAND FREEZER

## CHINESE STYLE TRANSPERENT

HN21A/ZTS-U

HN25A/ZTS-U

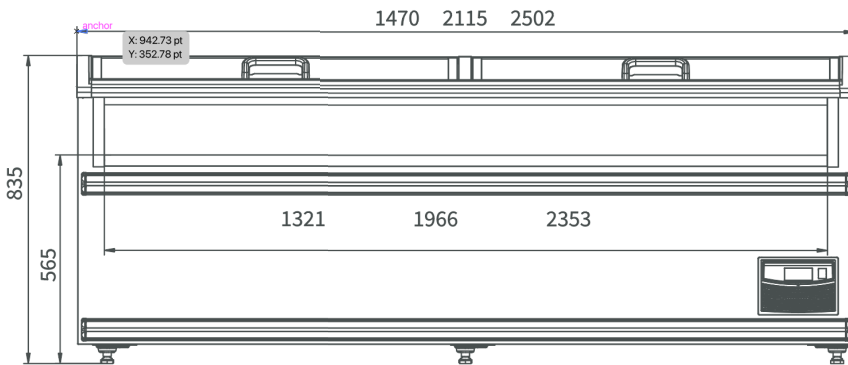

### Available Sizes

2115 Width	x	875 Length	x	835 Height
2502 Width	x	875 Length	x	835 Height

- Front transparent window
- Evaporator refrigerating
- 4 Layers front glass
- User-friendly handles
- The lowest temperature: -25°C
- RAL colour choices
- Larger opening area
- Auto defrosting

# STORAGE SHELVES

## Mini Storage

60cm

Width

x

2m

Length

x

2m

Height

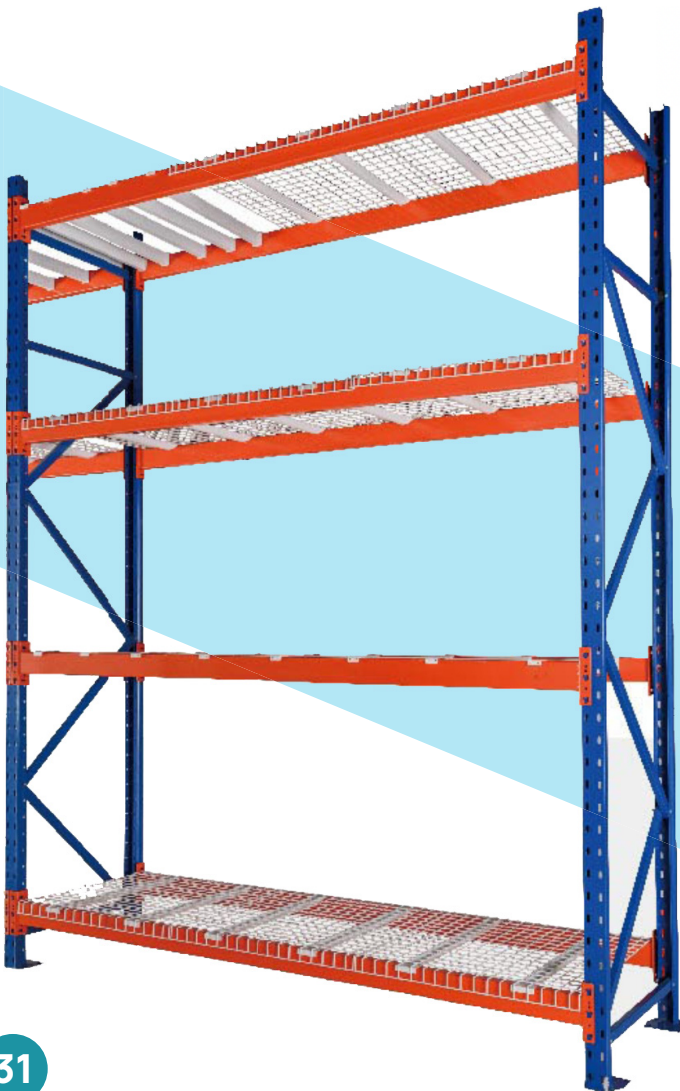

## Heavy Storage

90cm

Width

x

2.85m

Length

x

3m

Height

# STORAGE SHELVE



**German Tech  
Storage Shelves**



**Italian Tech  
Storage Shelves**



# STORAGE SOLUTIONS

## Grain/Nuts Dispensers



## Chips Baskets



## Baskets

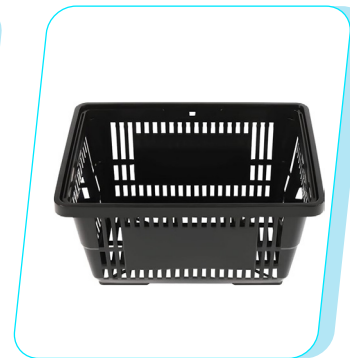

## Trolleys







# Unlock the Future

Connect with our expansive network and elevate your business by integrating the latest technological advancements. Discover unparalleled refrigeration and storage solutions that embody the pinnacle of innovation available for you today!

**Call & Book a Consultation Now!**

**+971 506 306 463**

**+971 555 772 835**



## **CHILL TECH**

Refrigeration & Cold Storage Trading LLC

**Ph. +971506306463, +971 55 577 2835**

Mail : [info@chilltechuae.com](mailto:info@chilltechuae.com)

Showroom No. 1, Abdulla Kamber Business Center  
Hor Al Anz, Near Abu Baker, Al Siddique Metro Station, Dubai